



## ENGINE

Make	: Mercedes-Benz 6R1100
Type	: OM470LA EU Stage IV Diesel Engine
Number of Cylinders	: 6 in line
Bore & Stroke	: 125 x 145 mm
Displacement	: 10.700 cc
Maximum Power	: 324 HP (242 kW) @ 1800 rpm
Maximum Torque	: 1600 Nm (1300 rpm)

High power and torque output, water cooled, turbocharged diesel engine.  
Conforms to European Stage IV exhaust gas emission regulations

## TRANSMISSION

- Autoshift transmission for heavy duty service
- 5 forward, 3 reverse gears
- Torque converter with 2.194:1 stall ratio
- 4 Wheel Drive
- Transmission oil cooler
- Engine start only at the gear lever on neutral position for safety.
- Electronic parking brake

## HYDRAULIC SYSTEM

Closed center type hydraulic system with LS type variable displacement piston type pumps.

Pump Flow (Pump 1)	: 190 l/min (1900 rpm)
Pressure (Pump 1)	: 250 bar
Pump Flow (Pump 2)	: 190 l/min (1900 rpm)
Pressure (Pump 2)	: 210 bar
Pump Flow (Pump 3)	: 85 l/min (1900 rpm)
Pressure (Pump 3)	: 250 bar

## DRIVING SPEED

At 1900 rpm engine speed

1 <sup>st</sup> gear	: 6,8	km/h
2 <sup>nd</sup> gear	: 11,7	km/h
3 <sup>rd</sup> gear	: 18,3	km/h
4 <sup>th</sup> gear	: 25,4	km/h
5 <sup>th</sup> gear	: 37,8	km/h

## AXLES

- Heavy duty type ZF axles
- Planetary type reduction gears
- Total 26 degrees oscillation on the rear axle
- Equipped with differential lock on the front axle

## CAB & HOOD

- Widened visual angle
- Ergonomic & Aesthetic Interior Design
- 8" LCD coloured touchpad display
- Improved Opera Control System
- Externally servicable Air Conditioner system
- Cool-box
- Electro hydraulic control levers
- ROPS and FOPS certificated cab
- 35° tilting cab for maintenance
- Air suspension seat with heating
- TIPSHIFT control on operator console
- Pool type floor mats
- Tablet PC and phone holder
- SmartLink (Optional)
- Storage boxes for operator
- Sun-wisors
- LED headlamps
- LED working lights
- Electrically controlled side mirrors with heating
- Rear view camera
- One-piece opening hood, electrically controlled.
- Independently adjustable joystick console and armed

## TIRES

Front / Rear : 26,5R25-L3

## OPERATING WEIGHT

Operating weight (with standard equipment) : 26.300 kg

# HMK 640 WL

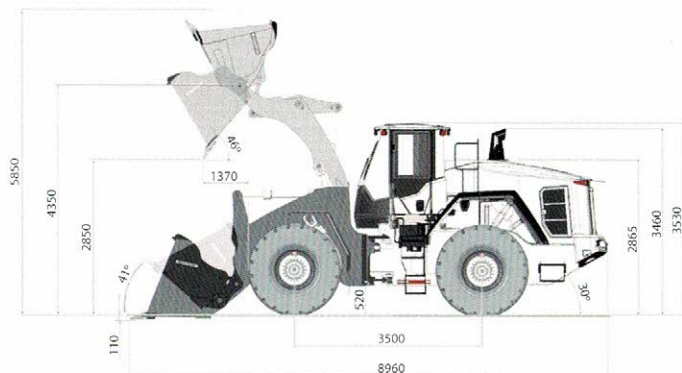
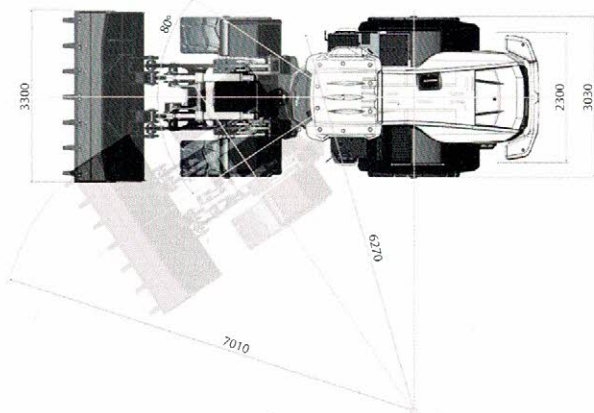

PERFORMANCE	
Bucket capacity (m <sup>3</sup> )	4,2
Max. breakout force (kgf)	19975
Static tipping load (no tire deflection) (kgf)	19269
Static tipping load- articulated (no tire deflection) (kgf)	17015

## Operator cab

- ROPS/FOPS
- Smartlink (Optional)
- Electronically controlled air conditioner
- Sliding side window
- Coat hook
- Single key (door/start)
- Viscous mounts
- Front and rear windshield wipers
- Dome light

## Linkage

- Double Z-bar
- Auto-lift
- Return to Dig (RTD)
- Auto bucket Kick-out

## Power Train

- 5 forward 3 reverse gear
- Torque converter
- Manually actuated differential lock
- SAHR type parking brake on transmission

## Hydraulics

- Load sensing steering and hydraulics
- Ride Control System (MSS)
- Proportional and bi-directional hydrostatic fan
- Emergency steering system
- Easy access to pressure measure mant points

## Electrical and Lighting

- 24 V
- Batteries 2 x 12 V, 1200 CCA
- Alternator, 100 Amp
- LED headlamps
- LED working lamps (4 front, 4 rear, 2 hood)
- LED stoplights
- Ignition key, start stop switch
- 12V outlet
- Reverse Alarm
- Main disconnect switch

## Others

- Air (engine/cab), transmission oil, hydraulic oil, engine oil filters
- Tool-box, lockable
- Radio with USB/AUX



Yard: 567 Don Buck Road, Westgate, Auckland 0614  
 09 838 0068 • magnumequipment.co.nz • magnumhire

100% NEW ZEALAND OWNED AND OPERATED

Notice:  
 HIDROMEK has the right to modify the specifications and design of the model indicated on this brochure without prior notice.